

# VUELTA SOFA

DESIGN: Jaime Hayon

Rotation, turning, return – these are the meanings of the Spanish word Vuelta. The backrest rotates playfully around the corner, becomes the armrest, continues on to the sitter - or recliner—in order to enclose them, as in an embrace. The special shape is divided by expertly crafted seam patterns, as a reminiscence of Josef Hoffmann.



# VUELTA *Design: Jaime Hayon*

25612

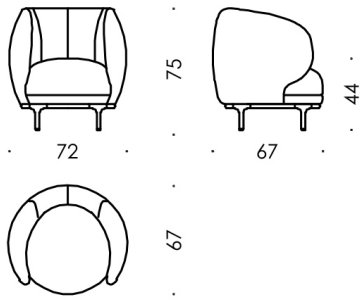

25613

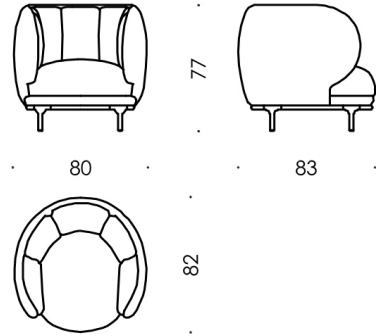

25601

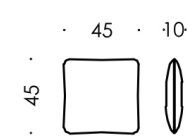

25602

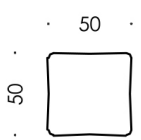

25620

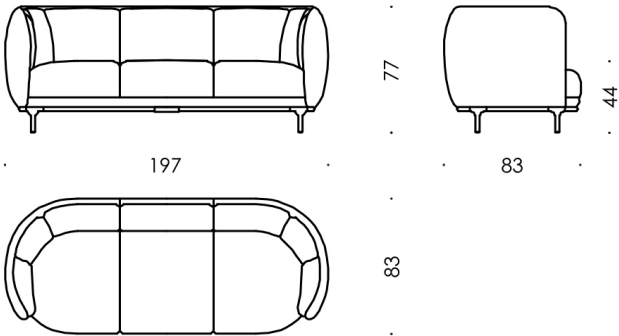

25625

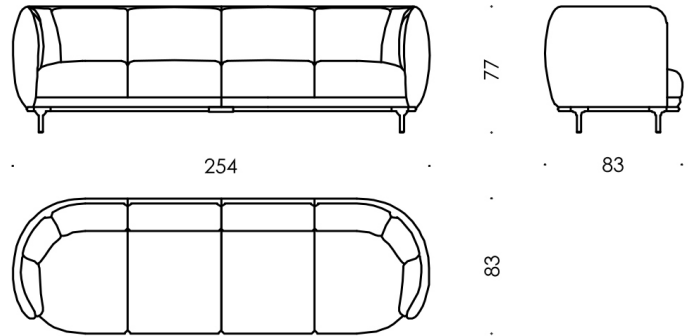

25630

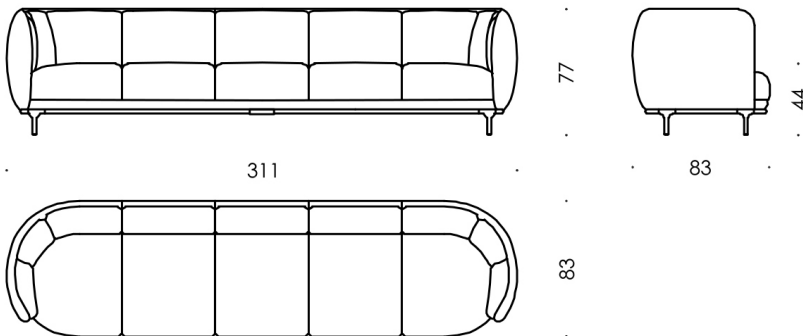

	25612	25613	25620	25625	25630
<b>Sitzbreite in cm:</b>	45	55	142	199	256
<b>seating width in cm:</b>	45	55	142	199	256
<b>Sitzbreite in inches:</b>	17,72	21,65	55,91	78,35	100,79
<b>seating width in inches:</b>	17,72	21,65	55,91	78,35	100,79
<b>Sitztiefe in cm:</b>	51	56	59	59	59
<b>seating depth in cm:</b>	51	56	59	59	59
<b>Sitztiefe in inches:</b>	20,08	22,05	23,23	23,23	23,23
<b>seating depth in inches:</b>	20,08	22,05	23,23	23,23	23,23
<b>w/h/d/sh in inches:</b>	28,35x29,53x26,38x17,32	31,50x30,31x32,28x17,32	77,56x30,31x32,68x17,32	100,00x30,31x32,68x17,32	122,44x30,31x32,68x17,32

**Technische Beschreibung:**

**Gestell:** Holzgestell mit Formholzschale  
**Gestell Fauteuil 76:** Metall-Holzkonstruktion  
**Füße:** Feinstrukturpulverbeschichtet Bronze, Dark grey, Black grey, Blue grey oder Light grey  
**Polsterung:**  
**Sitz:** Starre Begürtung, Federkern, Juteabdeckung  
 Polymousse-Sandwichaufbau, Vliesabdeckung  
**Schale:** Polymousse-Sandwichaufbau, Vliesabdeckung  
**Bezug:** Fixbezug

**technical description:**

**frame:** wooden frame with moulded wooden shell  
**frame fauteuil 76:** combined wooden and metal construction  
**legs:** fine structure powder coated Bronze, Dark grey, Black grey, Blue grey or Light grey coloured  
**upholstery:**  
**seat:** fixed webbing with coil springs, jute overlay, polyurethane foams sandwich layered, dacron overlay  
**shell:** polyurethane foams sandwich layered, dacron overlay  
**covers:** fixed covers

Falten sind design- verarbeitungs-, stoff-, bzw. benützungsbedingt und stellen keinen Reklamationsgrund dar.  
 Creases are due to design, workmanship and fabric, respectively use and are no cause for claims.